

BILL OF MATERIALS

REV	ITEM	PART	MATERIAL	QTY	REQUIRED SIZE (QUANTITIES ARE SHOWN FOR 1)	PART NUMBER
	1	OMEGA SPRING FLANGE	316SS	1	GA. 16 THK - OMEGA SPRING FLANGE P2 STD	OF STD 316SS
	2	OMEGA SPRING STRAP	SS	1	0.0315" THK. x 1" WIDTH OMEGA STRAP	OM 1 T301

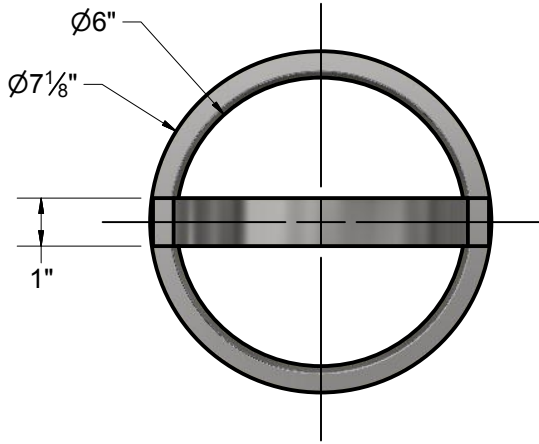

TOP VIEW

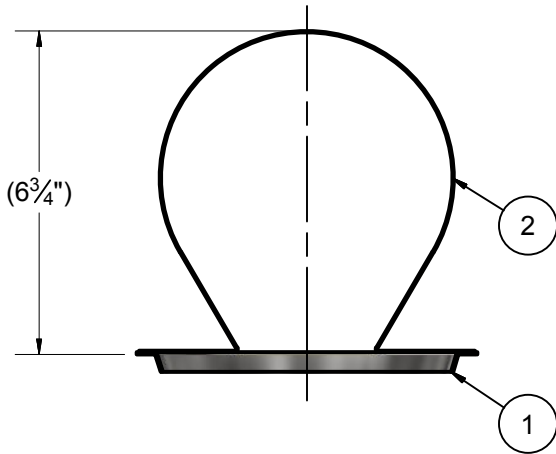
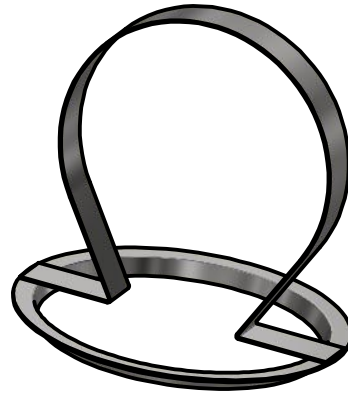

FRONT VIEW

CUSTOMER:	
CUSTOMER P.O.:	
QUANTITY:	
FSI WORK ORDER NO.:	
MATERIAL OF CONSTRUCTION:	SEE BOM
APPROVED FOR FABRICATION:	

TOLERANCE (EXCEPT AS NOTED)	REVISIONS		
	NO.	DATE	BY
DECIMAL ± 0.125"			
FRACTIONAL ± 3/8"			
ANGULAR ± 1'			

# FILTER SOLUTIONS INC.

BURLINGTON, ONTARIO, CANADA

TITLE <b>BASKET OMEGA SPRING P1/P2 STD</b>			
DRAWN: KN	DATE: JULY-10-2015	DWG NO	REV
CHECKED: FSI	DATE: JULY-10-2015	OS SE S 316	0
APPROVED: FSI	SCALE: 1:4	SHEET 1 OF 1	